

NOTES:

1. TO INSPECT ASSEMBLY, FOLLOW FIRST ARTICLE AND IN PROCESS INSPECTION SHEET.

- 2. APPLY LOCTITE 680.
- 3. SLIT AND SHORTEN O-RING BY .13" TO .20" IN LENGTH BEFORE INSTALLING.
- 4. SLIT O-RING BEFORE INSTALLING.
- 5. INSTALLATION TORQUE: 8 - 14 LB-FT.
- 6. WATER TEST WHOLE UNIT.
- 7. SEE DETAIL 'A' FOR INSTALLATION ORIENTATION.
- 8. BAG 5-007 IN A SEPARATE BAG.
- 9. APPLY THIN FILM OF DOW CORNING 111.
- 10. APPLY LOCTITE 242.
- 11. INSTALLATION TORQUE: 10 - 14 LB-IN.

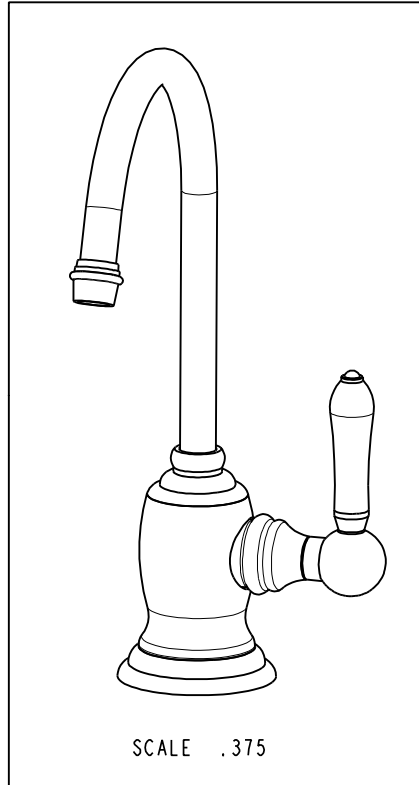

BILL OF MATERIAL (CURRENT LEVEL)

ITEM	PT/ASSY	DESCRIPTION	TYPE	QTY.
1	12716	ESCUTCHEON	PART	1
2	50703	WATER DISP. BODY (TRAD.)	PART	1
3	50705	WATER DISP BODY CAP	PART	1
4	50706	WATER DISP SPOUT RET RING	PART	1
5	50713	SPOUT, WATER DISP. (TRAD.)	PART	1
6	50712	WATER DISP SPOUT SHELL	PART	1
7	91382	O-RING, #2- 012, TEFLON,	PART	1
8	91217	O-RING, #2-020, EPDM, 65-75 DURO, NSF 61	PART	1
9	91017	O-RING, #2- 012, EPDM, 65-75 DURO, NSF 61	PART	2
10	50714	WATER DISP. CAR.T HOLDER	PART	1
11	1-134	CARTR 3/8 HOT 1/4 TR	PART	1
12	50708	WATER DISP HDL BONNET (TRAD)	PART	1
13	91383	O-RING, #2- 014, TEFLON, NSF 61	PART	1
14	50760	NIPPLE WATER DISP	PART	1
15	10661	MOUNTING STUD	PART	1
16	10514	MOUNTING CRESCENT	PART	1
17	91063	MOUNTING CRESCENT GASKET	PART	1
18	10516	MOUNTING NUT	PART	1
19	91762	O-RING, #2-132, EP, 50 DURO - GREY	PART	1
20	5-007	1/4 COMP KIT	ASSEMBLY	1
21	11833	ADAPTER	PART	1
22	92477	SCRW, M4 X 16 SKT FLT HD SS	PART	1
23	12589	WATER DISP LEVER HUB (TRAD)	PART	1
24	92000	SCREW 8 - 32 X 1/8 SS	PART	1
25	92192	SCRW, 10-32 X 5/8 SKT HD CUP PT SS	PART	1
26	12583	LEVER HANDLE	PART	1

ZONE	REV	DESCRIPTION	DATE	APPROVED
-	C	EN-4300jj	04/12/21	R.S.
-	B	EN-3722	02/08/19	C.G.
-	A	EN-3240	01/05/17	V.V.
-	-	EN-2980i	10/4/16	J.A.

COPYRIGHT 2005 BRASSTECH, INC. THESE DRAWINGS AND THE DESIGNS DEPICTED HEREIN ARE THE PROPRIETARY PROPERTY OF BRASSTECH. ANY USE OR REPRODUCTION IS SUBJECT TO THE EXPRESS APPROVAL OF BRASSTECH. UNAUTHORIZED USE IS STRICTLY PROHIBITED. ALL RIGHTS RESERVED.

TESTING	-	-	-
ASSEMBLY	-	-	-
PLATING	-	-	-
POLISHING	-	NEXT ASSY	USED ON
MACHINING	-	APPLICATION	
TOOLING FIXTURE #	REMOVE ALL BURRS AND SHARP EDGES		

UNITS ARE: INCHES [MM]
TOLERANCES ARE:
FRACTIONS DECIMALS ANGLES
±1/16" .X ±.1 [2,5] ±1°
.XX ±.06 [1,5]

(X.XXX) DENOTES CRITICAL DIMS.
ALL THREADS ARE CRITICAL

DRAWN	JINSON	04/12/21
CHECKED	R.S.	04/12/21
APPROVED	R.S.	04/12/21

BRASSTECH 2001 CARNEGIE AVE.
INCORPORATED SANTA ANA, CA 92705
(949) 417-5207

COLD WATER DISP, LEVER
TRAD

DWG NO.	1030-5623	REV	C
SCALE	.300	REF.	-
SHEET	1	OF	3

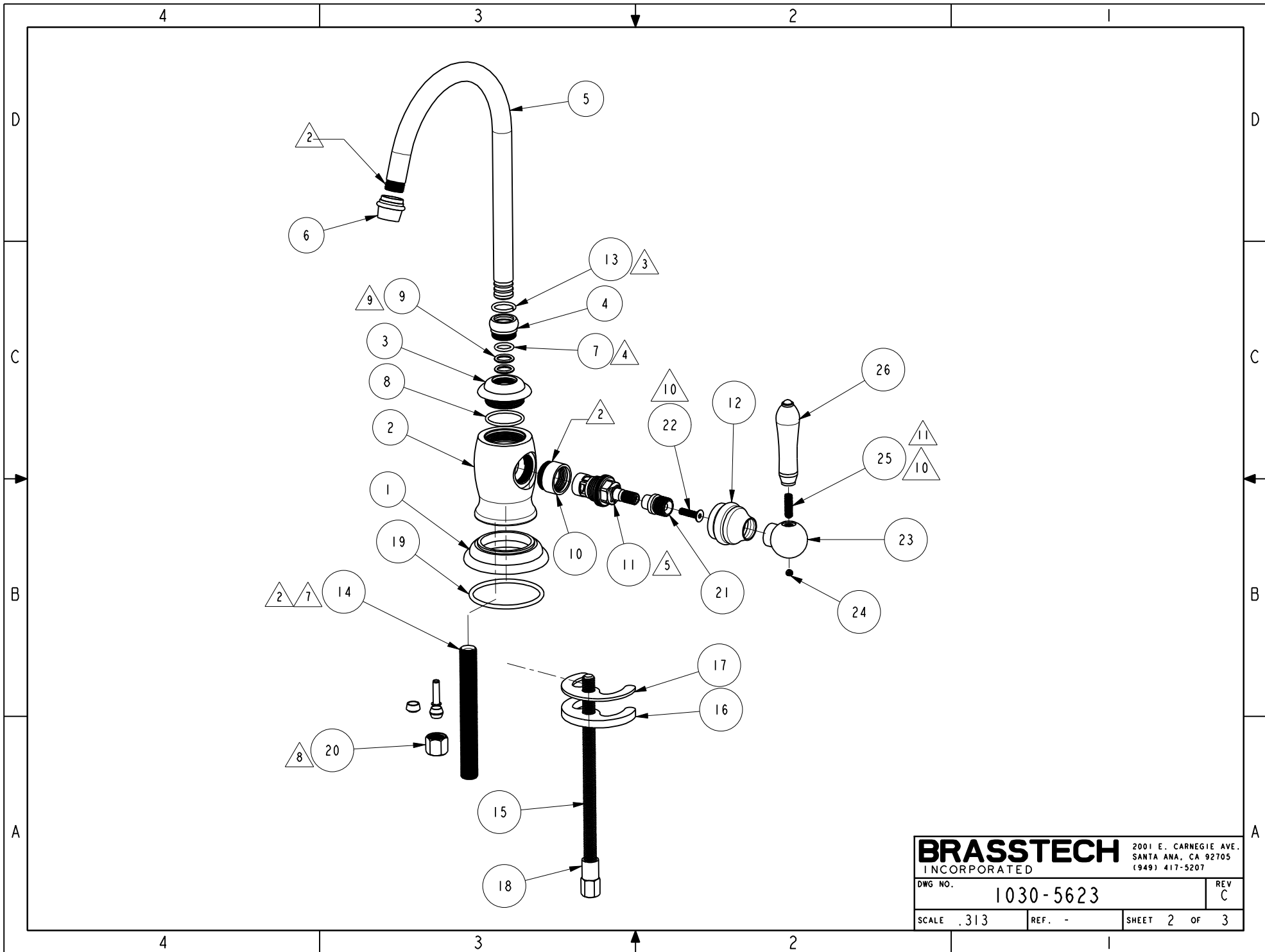

BRASSTECH 2001 E. CARNEGIE AVE.
 INCORPORATED SANTA ANA, CA 92705
 (949) 417-5207

DWG NO.	1030-5623	REV	C
SCALE	.313	REF.	-
SHEET 2		OF 3	

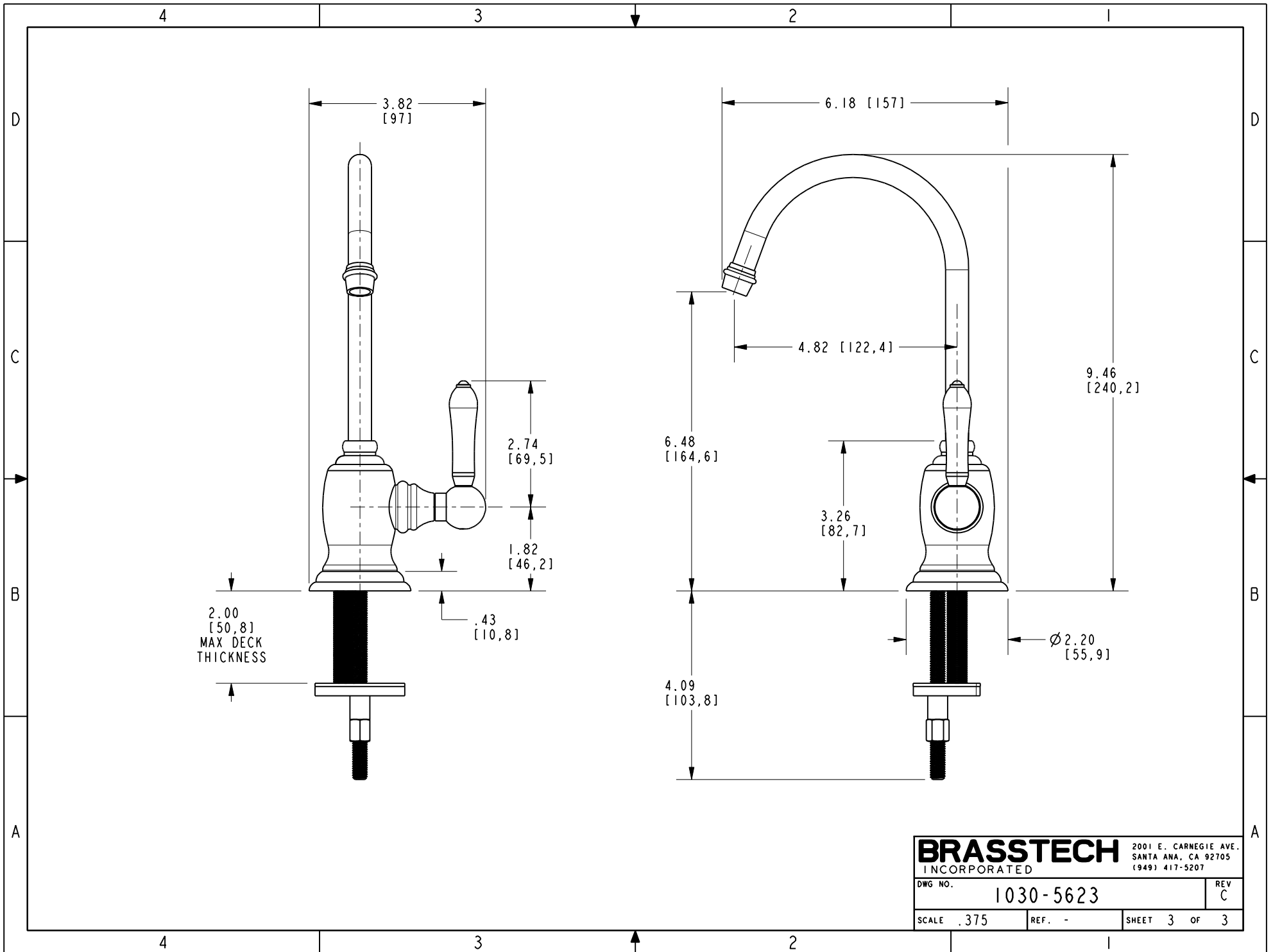

BRASSTECH		2001 E. CARNEGIE AVE. SANTA ANA, CA 92705 (949) 417-5207
DWG NO.	1030-5623	REV C
SCALE .375	REF. -	SHEET 3 OF 3